

EARLY TENSION LOSS IN AN ANTERIOR CRUCIATE LIGAMENT GRAFT

A CADAVER STUDY OF FOUR TIBIAL FIXATION DEVICES

BY DUSTIN M. GROVER, MS, STEPHEN M. HOWELL, MD, AND MAURY L. HULL, PHD

Investigation performed at the Department of Mechanical Engineering, University of California, Davis, California

Background: The tensile force applied to an anterior cruciate ligament graft determines the maximal anterior translation; however, it is unknown whether the tensile force is transferred to the intra-articular portion of the graft and whether the intra-articular tension and maximal anterior translation are maintained shortly after ligament reconstruction.

Methods: Ten cadaveric knees were reconstructed with a double-looped tendon graft. The graft was looped through a femoral fixation transducer that measured the resultant force on the proximal end of the graft. A pneumatic cylinder applied a tensile force of 110 N to the graft exiting the tibial tunnel with the knee in full extension. The graft was fixed sequentially with four tibial fixation devices (a spiked metal washer, double staples, a bioabsorbable interference screw, and a WasherLoc). Three cyclic loading treatments designed to conservatively load the graft and its fixation were applied.

Results: The combined loss in intra-articular graft tension from friction, insertion of the tibial fixation device, and three cyclic loading treatments was 50% for the spiked washer ($p = 0.0004$), 100% for the double staples ($p < 0.0001$), 64% for the interference screw ($p = 0.0001$), and 56% for the WasherLoc ($p < 0.0001$). The tension loss caused an increase in the maximal anterior translation from that of the intact knee of 2.0 mm for the spiked washer ($p = 0.005$), 7.8 mm for the double staples ($p < 0.0001$), 2.7 mm for the interference screw ($p = 0.001$), and 2.1 mm for the WasherLoc ($p < 0.0001$).

Conclusions: The tensile force applied to a soft-tissue anterior cruciate ligament graft is not transferred intra-articularly and is not maintained during graft fixation. The loss in tension is caused by friction in the tibial tunnel and wrapping the graft around the shank of the screw of the spiked washer, insertion of the tibial fixation device, and cyclical loading of the knee. The amount of tension loss is sufficient to increase the maximal anterior translation.

Clinical Relevance: Surgeons should pay close attention to the technique for inserting the tibial fixation device as this study supports the assumption that this step induces the greatest change and variability in the intra-articular tension and maximal anterior translation in the knee reconstructed with a double-looped tendon graft. Cyclically loading the knee causes a further loss in intra-articular tension and an increase in the maximal anterior translation, which can be reduced by the use of fixation devices that resist lengthening at the site of fixation and by limiting cyclic loading of the knee.

There is no agreement on the appropriate amount of tensile force to apply to an anterior cruciate ligament graft to restore stability to the knee¹. One reason for this is the conflicting results from clinical studies concerning the effect of the tensile force on stability of the knee. Two clinical studies have shown that the tensile force does not affect stability^{2,3}, whereas another has shown that a high tensile force (80 N) increased stability at two years but that two lower tensile forces (40 and 20 N) did not⁴. Another reason for the lack of agreement is that the type of graft and the stiffness of the fixation device affect the amount of tensile force required to restore the stability to the knee. Cadaver studies have shown that different tensile forces are required for different types of

grafts (e.g., 16 N for bone-patellar tendon-bone, 38 N for doubled semitendinosus, and 61 N for an iliotibial band)⁵ and that the tensile force ranges from 73 to 242 N for fixation techniques that range in stiffness from 25 to 275 N/mm⁶.

Our study investigated another possible reason for the lack of agreement, which is that the tensile force applied to the graft might not be fully transferred to the intra-articular portion of the graft and might not be maintained. There are at least three possible reasons that the intra-articular tension could be less than the tensile force: (1) the frictional loss between the graft and the tibial tunnel⁷ and between the graft and the tibial fixation device, (2) the proximal displacement of the graft during insertion of the tibial fixation device⁷, and

(3) the elongation of the graft-fixation complex from cyclical loading of the knee⁸⁻¹⁰. This study evaluated the response of four tibial fixation devices commonly used with double-looped tendon grafts. The specific aims were to determine: (1) whether the tensile force applied to the graft by the surgeon is transferred to the intra-articular portion of the graft, (2) whether there is a loss in intra-articular graft tension while the fixation device is secured, (3) whether there is a loss in intra-articular graft tension while the knee is cyclically loaded following fixation, and (4) whether loss in intra-articular graft tension results in an increase in the maximal anterior translation.

Materials and Methods

Preparation of the Intact Knee

Ten cadaveric knees (average age of donors, sixty-five years; range, fifty-six to seventy-four years) were harvested and stored at -20°C . Radiographs and inspection of the knee at the time of anterior cruciate ligament reconstruction did not reveal moderate or severe degenerative arthritis, chondrocalcinosis, or torn menisci. The intact knee was thawed overnight. All soft tissue was removed 7 cm distal to and proximal to the knee joint line. The diaphysis of the femur was cut 20 cm proximal to the joint line, and a 12.7-mm-diameter, 28-cm-long steel rod was cemented inside the medullary canal of the femur to within 7.5 cm of the joint line. The diaphysis of the tibia was cut 18 cm distal to the joint line, and a 12.7-mm-diameter, 43-cm-long steel rod was cemented inside the medullary canal to within 7.5 cm of the joint line. The diaphysis of the femur was cemented in a 6.4-cm-diameter, 20-cm-long aluminum cylinder to a distance 6.4 cm proximal to the joint line.

The knee was placed supine in a custom-built six-degree-of-freedom testing apparatus that permitted unconstrained knee motion for flexion angles ranging from 30° to hyperextension. The testing apparatus was designed and built in our laboratory and was used for tensioning the graft, inserting

each tibial fixation device, measuring the resultant force on the proximal end of the graft, measuring the maximal anterior translation of the knee, and applying cyclic loading treatments to the knee (Fig. 1). The aluminum cylinder containing the femur was clamped in the femoral fixture, with the flexion-extension axis of the knee perpendicular to the sagittal plane. Motion of the tibia was unconstrained by attaching a low-friction bearing to the end of the steel rod extending from the tibia and resting the bearing on a low-friction Delrin plate (DuPont, Wilmington, Delaware). The length, ankle height, weight, and center of gravity of the tibia were set to that of the shank-foot complex of an 81-kg, 180-cm-tall man on the basis of anthropometric measurements¹¹⁻¹³. The length of the tibia-steel rod-low-friction bearing was set to 51.5 cm, and the height of the tibia anterior to the low-friction bearing was set to 2.9 cm, which represents the height of the ankle anterior to the heel. With use of an iterative protocol, a weight was attached to the tibia to set the weight of the shank and foot to 49 N and the center of gravity at 27.1 cm distal from the knee joint line. Applying blocks of different heights under the low-friction bearing set the flexion angle of the knee. Manual extension of the knee until resistance was felt defined full extension¹⁴. Knee flexion was measured with a goniometer (Stryker Howmedica, Mahwah, New Jersey) with an accuracy to within $\pm 1^{\circ}$.

Measurement of the Maximal Anterior Translation of the Intact Knee

The maximal anterior translation of the intact knee at 25° of flexion in response to a 134-N anterior load applied perpendicular to the longitudinal axis of the tibia was determined with a custom-made arthrometer with use of the loading protocol of a commercial arthrometer (KT-1000; MedMetric, San Diego, California) (Fig. 1). Three 89-N posterior loads were applied to the tibia. The removal of the third load defined the neutral position of the tibia. The maximal anterior translation was the difference in the position of the tibia

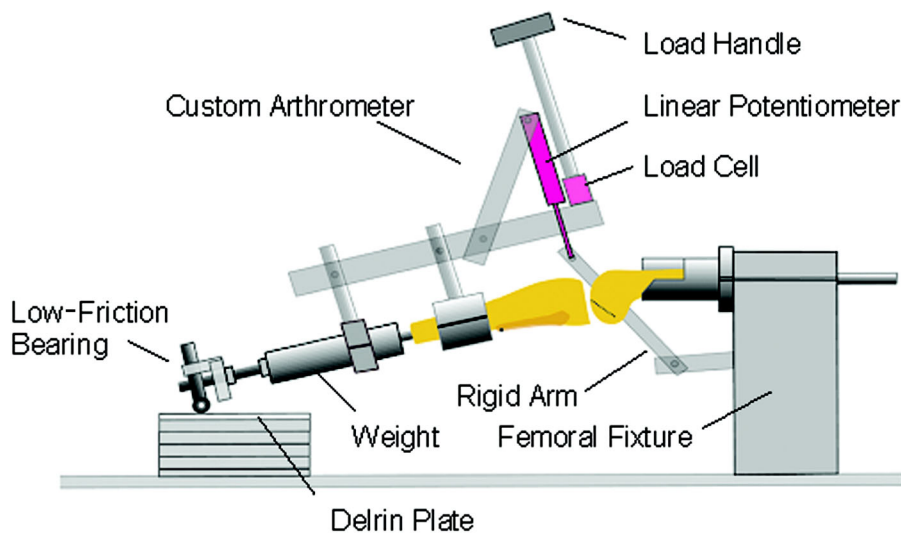

Fig. 1

Diagram showing the knee in 25° of flexion in the testing apparatus. The custom-made arthrometer is installed on the tibia with the load handle centered over the knee. Anterior and posterior loads are applied perpendicular to the longitudinal axis of the tibia by pulling and pushing on the load handle. A load-cell in series with the handle records the load. Anterior-posterior translation is measured with a linear potentiometer (ETI Systems, Carlsbad, California) placed over the knee joint line and connected to a rigid arm, which is connected to the femoral fixture.

in response to a 134-N anterior load compared with the neutral position.

Technique of Anterior Cruciate Ligament Reconstruction

The tibial metaphysis was reinforced with polyurethane foam to provide fixation properties in cadaveric tibiae from elderly individuals that were similar to those in tibiae from young individuals¹⁵. The anterior cruciate ligament was excised, and tibial and femoral drill-holes were made with use of a previously described transtibial technique that positions the graft without roof impingement, without impingement of the posterior cruciate ligament, and with a tension pattern that matches that of the intact anterior cruciate ligament¹⁶. The tibial tunnel was drilled to 8 mm in diameter and was serially dilated in 0.5-mm increments to 9 mm following the recommendation of the manufacturer of the interference screw. A femoral guide-pin was placed with use of a femoral aimer with a 5.5-mm offset that was inserted through the tibial tunnel and was hooked in the over-the-top position. An open-end femoral tunnel was drilled to 16 mm in diameter. The blow-out of the posterior wall of the femoral tunnel was later closed with bone cement. A low-friction femoral bushing with an outer diameter of 16 mm was machined from Delrin (Fig. 2). A 9-mm-diameter tunnel was drilled from distal to proximal through the central axis of the bushing to a depth of 10 mm. From the opposite end of the bushing, a 12.5-mm-diameter tunnel that stopped at the 9-mm-diameter was drilled. The bushing was inserted into the femoral tunnel until it was flush with the intercondylar roof and was fixed there with bone cement.

After the experiment was completed, an anteroposterior and lateral radiograph with the knee in full extension was used to verify that the tibial tunnel was properly placed in each knee. The tibial tunnel was imaged by placing a 9-mm-diameter stainless-steel rod (impingement rod; Arthrotek, Warsaw, Indiana) through the tibial tunnel and into the notch. In the coronal plane, the rod was centered between the tibial spines at a mean angle (and standard deviation) of $65^\circ \pm 3^\circ$ from the medial joint line of the tibia. In the sagittal plane, the rod grazed and was parallel to the intercondylar roof. The tension pattern of the graft matches the intact anterior cruciate ligament when the femoral tunnel is drilled through a tibial tunnel placed with these coronal and sagittal radiographic guidelines¹⁶. The foam-reinforced knee was then replaced in the testing apparatus. The femoral fixation transducer was made from stainless steel to glide with low friction in the 12.5-mm-diameter section of the femoral bushing (Fig. 2). A crossbar (stainless steel with a 2.4-mm diameter and 10-mm length) was welded to the distal end of the femoral fixation transducer to fix the double-looped tendon graft.

Forty double-looped tendon grafts were made from bovine extensor tendon¹⁵, which has structural properties similar to those of a double-looped semitendinosus and gracilis graft from a young human¹⁷. The tendons were trimmed until, when looped over a suture, they passed snugly through a 9-

mm-diameter cylinder and not through an 8-mm-diameter cylinder (Sizing Sleeve; Arthrotek). Four centimeters of the end of each strand were whip-stitched with use of a number-1 braided, absorbable suture (Polysorb; United States Surgical/Syneture, Norwalk, Connecticut)¹⁵. A fresh graft was selected at random for each test and was looped over the crossbar. The femoral fixation transducer and the graft were inserted into the femoral tunnel and were connected to a femoral load cell (225 N, SM-50; Interface, Scottsdale, Arizona). The femoral load-cell, which measured the resultant force on the proximal end of the graft, was connected to a turnbuckle that was connected to the base-plate of the testing apparatus. The turnbuckle was adjusted so that the crossbar was positioned to glide in the femoral bushing.

Insertion of the Tibial Fixation Devices

Four tibial fixation devices were tested in the following sequence on each of the ten knees: a spiked, metal soft-tissue washer (20-mm-diameter No-Profile Tissue Washer; Arthrotek), double staples (medium [11.11-mm] wide, 25.4-mm-long Richards fixation staples with spikes; Smith and Nephew Richards, Memphis, Tennessee), a bioabsorbable soft-tissue interference screw (11-mm-diameter, 35-mm-long Cannulated Delta Tapered Bio-Interference Screw; Arthrotek, Naples, Florida), and the WasherLoc (16-mm diameter; Arthrotek).

Three cyclic loading treatments were applied in succession to conservatively load the graft and all four fixation devices. Each cyclic loading treatment consisted of maintaining the knee in full extension for fifteen minutes and then flexing the knee to 25° and cyclically loading the knee twenty times

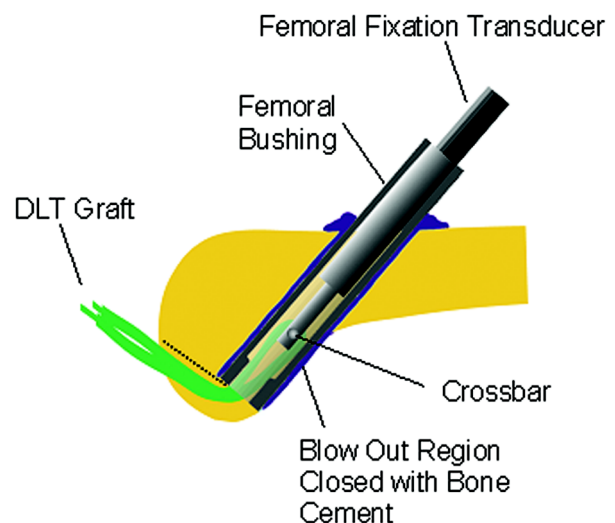

Fig. 2
Diagram showing the stainless-steel femoral fixation transducer positioned to glide inside the low-friction Delrin femoral bushing. The femoral bushing was cemented at the level of the intercondylar roof in the femoral tunnel with use of bone cement, which also closed the blow-out in the posterior wall. A turnbuckle attached to the femoral fixation transducer adjusted the depth of the crossbar in the femoral bushing. DLT = double-looped tendon.

between a posterior load of 26 N and an anterior load of 100 N. The anterior load of 100 N generated an intra-articular tension of 170 N in the graft, which is similar to the tension in the anterior cruciate ligament during level walking¹⁸. The resultant force on the proximal end of the graft and the maximal anterior translation were recorded after each cyclic loading treatment. For each tibial fixation, a fresh double-looped tendon graft was used.

The spiked washer was screwed partway into a tapped 4.5-mm bicortical drill-hole positioned 15 mm distal to the tibial tunnel on the anteromedial cortex. The knee was placed in full extension. Two tibial load-cells (225 N, SM-50; Interface) were used to apply the tensile force to the graft. Each tibial load-cell was connected to a pneumatic cylinder (Illinois Pneumatics, Roscoe, Illinois) mounted on a fixture connected to the base-plate of the testing apparatus proximal to the knee. For the spiked washer fixation, the tensile force was applied proximal to the knee. Two strands of one tendon were wrapped 180° clockwise, and the other two strands were wrapped 180° counterclockwise around the shank of the screw holding the spiked washer. The sutures from the two strands of each tendon were tied, and each loop of suture was hooked on a load-cell. The pneumatic cylinder attached to each tibial load-cell was adjusted to maintain a tensile force of 110 N, with an accuracy of ± 1 N. The femoral load-cell recorded the resultant force on the proximal end of the graft. The screw was firmly tightened, and the resultant force on the proximal end of the graft and the maximal anterior translation were recorded.

For the double staples, one pair of 1.9-mm-diameter cortical drill-holes was made 7 mm distal to the tibial tunnel on the anteromedial cortex with use of a drill-guide (medium width, fixation staple drill jig; Smith and Nephew Richards), and a second pair of drill-holes was made 6 mm distal to the first. The knee was placed in full extension. The tibial load-cells were repositioned distal to the knee, and a 110-N tensile force was applied to the graft at approximately 20° with respect to the surface of the anteromedial cortex of the tibia. The resultant force on the proximal end of the graft was recorded. The first staple was driven in the proximal drill-holes, and the second staple was driven in the distal drill-holes with use of a staple driver (fixation staple driver-extractor; Smith and Nephew Richards).

For the interference screw, the knee was placed in full extension. The tibial load-cells were repositioned distal to the knee, and a 110-N tensile force was applied to the graft in line with the long axis of the tibial tunnel. The resultant force on the proximal end of the graft was recorded. A 1.1-mm-diameter guide-pin was placed between the anterior wall of the tibial tunnel and the graft. The interference screw was inserted until the distal end of the screw was flush with the distal cortex of the tibial tunnel.

For the WasherLoc, a 17-mm-diameter counterbore was drilled into the distal end of the tibial tunnel. The tibial load-cells were positioned distal to the knee, and a 110-N tensile force was applied to the graft in line with the tibial tunnel. The

resultant force on the proximal end of the graft was recorded. The WasherLoc was threaded on a drill sleeve, and the drill sleeve was threaded on an awl. The awl was positioned in the hole created by the counterbore, and one strand from each tendon was placed on opposite sides of the awl. Striking the awl with a mallet drove the WasherLoc into the bone within the counterbore. A 6.5-mm-diameter, self-tapping cancellous screw was inserted through the WasherLoc and was tightened to fix the graft.

Correction for Frictional Loss in the Femoral Tunnel

For each reconstructed knee, the resultant force on the proximal end of the graft was corrected for frictional loss in the femoral tunnel with use of a correction ratio, which yielded the intra-articular graft tension. The correction ratio was determined at the end of each experiment after removing the tibia from the femur. A double-looped tendon graft was inserted in the femoral tunnel, and the graft was oriented parallel and adjacent to the intercondylar roof to position the graft as it was positioned during measurements of graft tension with the knee in full extension. A tensile force of 100 N was applied to the distal end of the graft, and the resultant force on the proximal end of the graft was recorded with the femoral fixation transducer. The correction ratio was equal to 100 N divided by the resultant force on the proximal end of the graft. The resultant force on the proximal end of the graft during each experiment was multiplied by the correction ratio to yield the intra-articular graft tension.

Statistical Analysis

For each tibial fixation device, the intra-articular tension measured after the third cyclic loading treatment (i.e., the final measurement) was compared, with use of a one-sample t test, with the tensile force. To determine whether friction caused a loss in intra-articular tension, the intra-articular tension measured after applying the tensile force (i.e., the first measurement) was compared, with use of a one-sample t test, with the tensile force. To determine whether inserting the tibial fixation device and each cyclic loading treatment caused a loss in intra-articular tension, a one-factor repeated-measures analysis of variance was used, with the independent variable consisting of five levels (applying the tensile force, inserting the tibial fixation device, the first cyclic loading treatment, the second cyclic loading treatment, and the third cyclic loading treatment) and with the dependent variable being intra-articular tension.

For each tibial fixation device, a one-sample t test was used to compare the maximal anterior translation after the third cyclic loading treatment and that of the intact knee. A one-sample t test was also used to compare the maximal anterior translation after inserting the tibial fixation device and that of the intact knee. To determine whether each cyclic loading treatment increased the maximal anterior translation, a one-factor repeated-measures analysis of variance was used, with the independent variable having four levels (after insert-

ing the tibial fixation device, after the first cyclic loading treatment, after the second cyclic loading treatment, and after the third cyclic loading treatment) and with the dependent variable being the difference in the maximal anterior translation of the reconstructed knee from that of the intact knee. Significant main effects were further analyzed with the Tukey test. The level of significance was set at $p < 0.05$.

Results

Spiked Washer

For the spiked washer, there was a 50% loss in intra-articular tension from the 110-N tensile force applied to the graft and the third cyclic loading treatment ($p = 0.0004$) (Fig. 3). Friction from the tibial tunnel as a result of wrapping the graft around the shank of the screw caused a loss in intra-articular tension to a mean (and standard deviation) of 32 ± 6 N (range, 19 to 39 N) ($p < 0.0001$). Inserting the spiked washer increased the intra-articular tension to a mean of 111 ± 30 N (range, 58 to 148 N) ($p < 0.05$). The first cyclic loading treatment caused a loss in intra-articular tension to a mean of 79 ± 32 N (range, 28 to 142 N) ($p < 0.05$), the second cyclic loading treatment did not change the intra-articular tension (mean, 65 ± 33 N; range, 21 to 137 N), and the third cyclic loading treatment did not change the intra-articular tension (mean, 55 ± 32 N; range, 16 to 126 N).

The difference in the maximal anterior translation of the reconstructed knee after insertion of the spiked washer and that of the intact knee was 0.0 ± 1.4 mm (range, -2.9 to 1.9 mm) ($p = 1.0000$), which increased to 2.0 ± 1.7 mm (range, -1.3 to 4.3 mm) after the third cyclic loading treatment ($p = 0.005$). The maximal anterior translation had not

stabilized by the third cyclic loading treatment ($p < 0.05$) (Fig. 3).

Double Staples

For the double staples, there was a 100% loss in intra-articular tension from the 110-N tensile force applied to the graft and the third cyclic loading treatment ($p < 0.0001$) (Fig. 4). Friction from the tibial tunnel caused a loss in intra-articular tension to a mean of 82 ± 6 N (range, 70 to 88 N) ($p < 0.0001$). Inserting the staples caused a further loss in intra-articular tension to a mean of 52 ± 10 N (range, 39 to 70 N) ($p < 0.05$). The first cyclic loading treatment caused a further loss in intra-articular tension to a mean of 1.6 ± 1.3 N (range, 0 to 4.3 N) ($p < 0.05$), the second cyclic loading treatment did not change the intra-articular tension (mean, 0.8 ± 0.8 N; range, 0 to 2.2 N), and the third cyclic loading treatment did not change the intra-articular tension (mean, 0.3 ± 0.5 N; range, 0 to 1.1 N).

The difference in the maximal anterior translation of the reconstructed knee after insertion of the double staples from that of the intact knee was a mean of 2.8 ± 1.1 mm (range, 1.6 to 4.9 mm) ($p < 0.0001$), which further increased to a mean of 7.8 ± 1.9 mm (range, 5.3 to 10.7 mm) ($p < 0.0001$) after the third cyclic loading treatment. The maximal anterior translation stabilized by the second cyclic loading treatment ($p \geq 0.05$) (Fig. 4).

Interference Screw

For the interference screw, there was a 64% loss in intra-articular tension from the 110-N tensile force applied to the graft and the third cyclic loading treatment ($p = 0.0001$) (Fig. 5). Friction

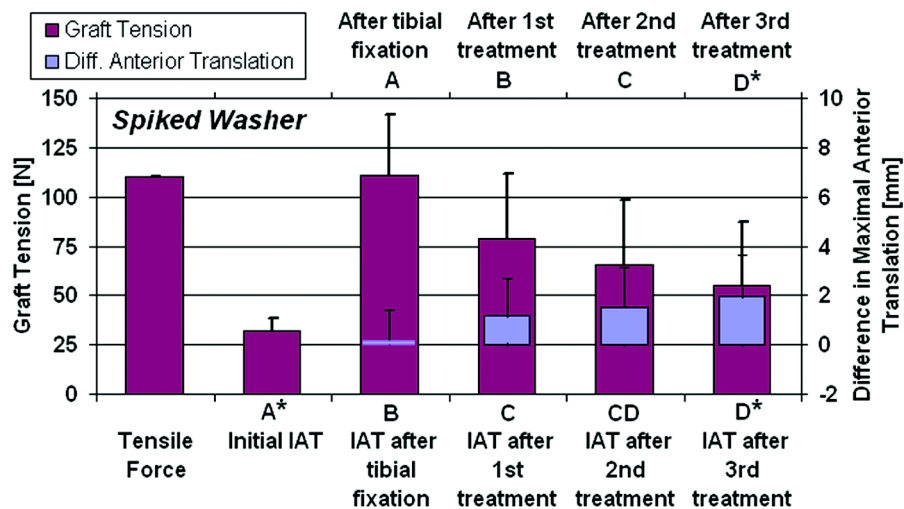

Fig. 3

The mean graft tension and the difference in the maximal anterior translation of the reconstructed knee after fixation with the spiked washer from that of the intact knee for each of the test conditions. Data points with different letters are significantly different. The asterisk indicates a significant difference between the applied tensile force and the intra-articular tension (IAT; lower axis) and between the maximal anterior translation of the intact knee and the reconstructed knee (upper axis) ($p < 0.05$). Error bars indicate one standard deviation.

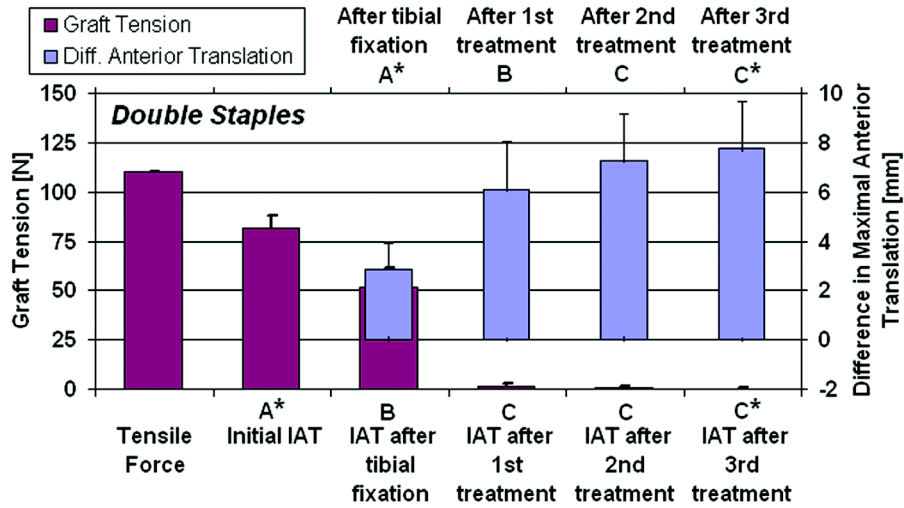

Fig. 4
The mean graft tension and the difference in the maximal anterior translation of the reconstructed knee after fixation with the double staples from that of the intact knee for each of the test conditions. Data points with different letters are significantly different. The asterisk indicates a significant difference between the applied tensile force and the intra-articular tension (IAT; lower axis) and between the maximal anterior translation of the intact knee and the reconstructed knee (upper axis) ($p < 0.05$). Error bars indicate one standard deviation.

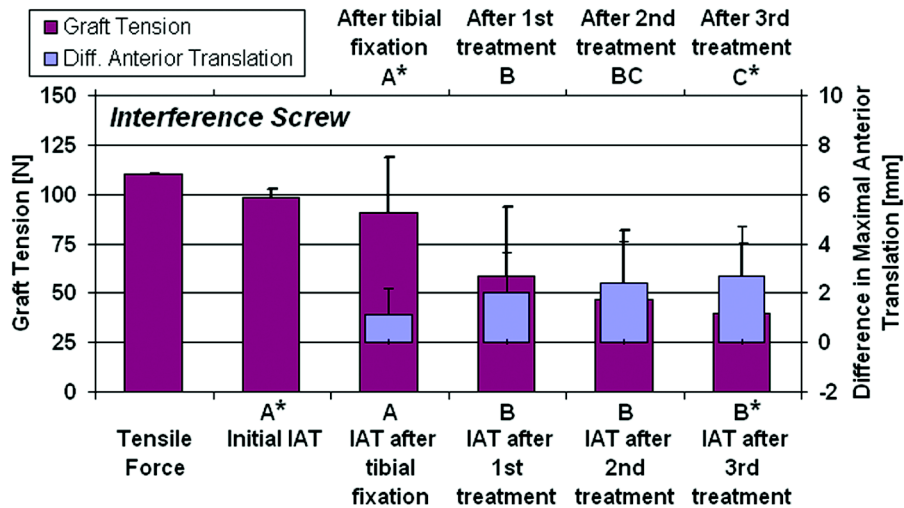

Fig. 5
The mean graft tension and the difference in the maximal anterior translation of the reconstructed knee after fixation with the interference screw from that of the intact knee for each of the test conditions. Data points with different letters are significantly different. The asterisk indicates a significant difference between the applied tensile force and the intra-articular tension (IAT; lower axis) and between the maximal anterior translation of the intact knee and the reconstructed knee (upper axis) ($p < 0.05$). Error bars indicate one standard deviation.

tion from the tibial tunnel caused a loss in intra-articular tension to a mean (and standard deviation) of 98 ± 4 N (range, 89 to 104 N) ($p < 0.0001$). Insertion of the interference screw did not change the intra-articular tension (mean, 91 ± 28 N; range, 58 to 141 N). The first cyclic loading treat-

ment caused a further loss in intra-articular tension to a mean of 58 ± 35 N (range, 10 to 117 N) ($p < 0.05$), the second cyclic loading treatment did not change the intra-articular tension (mean, 47 ± 35 N; range, 2 to 108 N), and the third cyclic loading treatment did not change the intra-articular

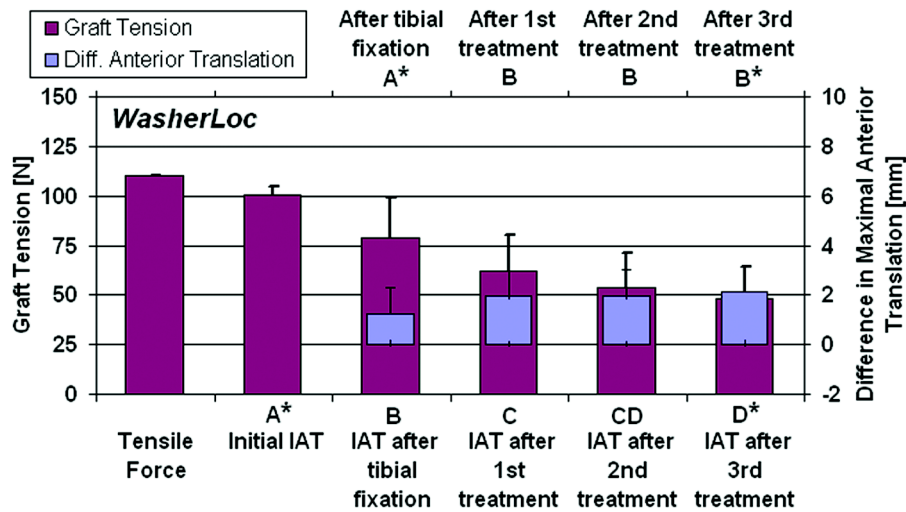

Fig. 6

The mean graft tension and the difference in the maximal anterior translation of the reconstructed knee after fixation with the WasherLoc and that of the intact knee for each of the test conditions. Data points with different letters are significantly different. The asterisk indicates a significant difference between the applied tensile force and the intra-articular tension (IAT; lower axis) and between the maximal anterior translation of the intact knee and the reconstructed knee (upper axis) ($p < 0.05$). Error bars indicate one standard deviation.

tension (mean, 40 ± 34 N; range, 1 to 105 N).

The difference in the maximal anterior translation of the reconstructed knee after insertion of the interference screw and that of the intact knee was a mean of 1.1 ± 1.1 mm (range, -0.4 to 3.1 mm) ($p = 0.011$), which further increased to a mean of 2.7 ± 2.0 mm (range, 0.2 to 7.4 mm) ($p = 0.001$) after the third cyclic loading treatment. The maximal anterior translation stabilized by the second cyclic loading treatment ($p \geq 0.05$) (Fig. 5).

WasherLoc

For the WasherLoc, there was a 56% loss in intra-articular tension from the 110-N tensile force applied to the graft and the third cyclic loading treatment ($p < 0.0001$) (Fig. 6). Friction from the tibial tunnel caused a loss in intra-articular tension to a mean of 100 ± 4 N (range, 93 to 107 N) ($p < 0.0001$). Inserting the WasherLoc caused a further loss in intra-articular tension to a mean of 79 ± 20 N (range, 41 to 112 N) ($p < 0.05$). The first cyclic loading treatment caused a further loss in intra-articular tension to a mean of 62 ± 18 N (range, 23 to 88 N) ($p < 0.05$), the second cyclic loading treatment did not change the intra-articular tension (mean, 54 ± 18 N; range, 17 to 81 N), and the third cyclic loading treatment did not change the intra-articular tension (mean, 48 ± 16 N; range, 15 to 71 N).

The difference in the maximal anterior translation of the reconstructed knee after insertion of the WasherLoc and that of the intact knee was a mean of 1.3 ± 1.0 mm (range, -0.9 to 2.6 mm) ($p = 0.0039$), which further increased to a mean of 2.1 ± 1.0 mm (range, 0.1 to 3.7 mm) ($p < 0.0001$) after the third cyclic loading treatment. The maximal ante-

rior translation stabilized by the first cyclic loading treatment ($p \geq 0.05$) (Fig. 6).

Discussion

In our opinion, there are four implicit assumptions in the selection of a tensile force at the time of anterior cruciate ligament reconstruction: (1) the tensile force applied to the graft distal to the tibial tunnel is transferred without change to the intra-articular portion of the graft, (2) the intra-articular tension is maintained after insertion of the tibial fixation device, (3) the intra-articular tension is maintained after cyclic loading of the knee, and (4) the intra-articular tension restores the maximal anterior translation to that of the intact knee. The present study shows that the tensile force applied to a double-looped tendon graft is not transferred intra-articularly, that the intra-articular tension is not maintained after the insertion of a tibial fixation device and cyclic loading of the knee, and that the loss in intra-articular tension increases the maximal anterior translation. The clinical relevance of these results is that a single value for a tensile force cannot restore the maximal anterior translation when knees with a torn anterior cruciate ligament are reconstructed with a double-looped tendon graft.

The first reason that a single value for a tensile force does not restore the maximal anterior translation is that the direction in which the tensile force is applied with respect to the knee and the type of fixation device have different effects on the transfer of the tensile force to the intra-articular portion of the graft. The application of the tensile force distal to the knee with the double staples, interference screw, and WasherLoc caused a 10% to 26% frictional loss between the

graft and the tibial tunnel. The application of the tensile force proximal to the knee with the spiked washer caused a 71% frictional loss between the graft and the shank of the screw. Therefore, the frictional loss between the graft and the tibial tunnel is determined by the direction of the tensile force and the type of fixation device.

The second reason that a single value for a tensile force does not restore the maximal anterior translation is that the insertion of the tibial fixation device causes variability in the intra-articular tension. For each fixation device, the mean intra-articular tension varied widely among the knees (111 N after fixation with a spiked washer, 52 N after use of double staples, 91 N with the interference screw, and 79 N with the WasherLoc), which also caused wide variability in the mean maximal anterior translation (0.0 mm after fixation with a spiked washer, 2.8 mm after use of double staples, 1.1 mm with the interference screw, and 1.3 mm with the WasherLoc). The surgeon should be mindful of the technique used to insert a tibial fixation device because the technique changes intra-articular tension¹⁹ and anterior translation.

The final reason that a single value for a tensile force does not restore the maximal anterior translation is that cyclic loading causes a loss in intra-articular tension. The loss in intra-articular tension from the three cyclic loading treatments increased the mean maximal anterior translation (2 mm for the spiked washer, 5 mm for the double staples, 1.6 mm for the interference screw, and 0.8 mm for the WasherLoc). The increase in anterior translation from cyclic loading is likely from lengthening at the two sites of fixation (e.g., slippage and contact deformation)¹⁰.

A limitation of this *in vitro* study is that the loss in intra-articular tension and the increase in the maximal anterior translation that could occur *in vivo* might have been underestimated. One reason for this is that resumption of the activities of daily living and aggressive rehabilitation place more tensile load on the knee than the three brief, conservative cyclic loading treatments used in the present study. A more sustained or higher tensile load on the knee, such as those from the activities of daily living and aggressive rehabilitation, might cause more lengthening at the sites of fixation¹⁰. Six weeks of performing the activities of daily living corresponds to approximately 220,000 cycles to the anterior cruciate ligament²⁰ at a tensile load of 169 N¹⁸. Animal studies have shown that fixation devices provide a substantial proportion of the fixation until four to eight weeks after surgery, after which the fixation transfers to the biologic bond between the graft and the bone tunnel²¹⁻²³. Since patients with a soft-tissue graft begin walking without crutches and a brace and resume exercise within the first week after surgery^{24,25}, the increase in maximal anterior translation from slippage at the site of fixation might be greater *in vivo* than in our study.

A second reason for this underestimation of tension loss is that there might be a greater loss in intra-articular tension *in vivo* with the use of a femoral fixation device that allows more lengthening at the femoral site of fixation than the crossbar used in the present study. Femoral fixation devices, such as

a suture bridge, either attached to a button or tied to a post (closed-loop and open-loop Endobutton; Acuflex Microsurgical, Mansfield, Massachusetts); interference screws (BioScrew [Linvatec, Largo, Florida] and RCI [Acuflex Microsurgical]); and two cross pins that skewer the graft (RIGIDfix cross-pin guide; Mitek Products, Norwood, Massachusetts) allow substantially more lengthening under cyclic load at the site of fixation than the crossbar used in the present study^{26,27}.

The observation that intra-articular tension is lost from friction in the tibial tunnel, insertion of the tibial fixation device, slippage at the site of tibial and femoral fixation, and from activities of daily living raises the possibility of compensating for the loss by using a higher tensile force. Compensating for the loss in tension depends on predicting (1) the loss in tension from each of these causes and (2) the intra-articular tension required to restore the maximal anterior translation. Predicting the loss in tension is a daunting, if not impossible, task because the tension loss from friction depends on the tightness of fit between the graft and the tunnel, the coarseness of the bone lining the tunnel^{28,29}, and the angle of the wrap with respect to the long axis of the tunnel²⁸. The tension loss from inserting the tibial fixation device varies widely even with careful surgical technique, and the tension loss from activities of daily living and aggressive rehabilitation is not quantifiable with any current methods. Predicting the intra-articular tension required to restore the maximal anterior translation for a given knee is not possible because the tension is not the same for every fixation device and every knee. A post hoc analysis revealed that the intra-articular tension that restored the maximal anterior translation varied from 82 to 230 N for the spiked washer, from 98 to 224 N for the double staples, from 110 to 243 N for the interference screw, and from 116 to 222 N for the WasherLoc. Considering these complexities, it is unlikely that a single value of tensile force can be used for every knee.

One assumption of the experiment was that the use of a tensile force of 110 N was sufficient to restore the maximal anterior translation of the intact knee. The choice of a tensile force of 110 N was considered to be appropriate for the following reasons. First, the results from a pilot study, involving three specimens, demonstrated that an intra-articular tension of 110 N with the knee in full extension was the average tension required to restore the maximal anterior translation to within ± 0.5 mm of that of the intact knee for the four fixation devices before cyclic loading of the knee. Second, an intra-articular tension of 110 N with the knee in full extension matched the anterior laxity of the intact knee with a double-looped tendon graft in an *in vitro* study¹⁶.

A second assumption of the experiment was that the nonrandomized, sequential testing of the four tibial fixation devices did not cause carryover effects that affected the loss in intra-articular tension. A carryover effect might have occurred for the double staples, interference screw, and WasherLoc if the insertion and removal of the preceding fixation device fractured the bone. A fracture in the bone did not occur because the three cyclic loading treatments were conservative in

that the applied load was well below the yield load of the fixation device in the foam-reinforced tibia¹⁵, and the bone was drilled and tapped before inserting the spiked washer and screw and was drilled before impacting the double staples. The condition of the bone was visually inspected after removal of each device, and the cortex was observed to be intact. Considered together, this experimental approach and the visual observations suggest that sequential, nonrandomized testing of the four fixation devices did not lead to bone fracture and therefore did not produce carryover effects that affected the loss in intra-articular tension.

A third assumption of the experiment was that the loss in intra-articular tension and the increase in the maximal anterior translation were similar to those that would be found in knees in young individuals. The loss in intra-articular tension and the increase in the maximal anterior translation might have been less if knees from young individuals had been used instead of knees from elderly individuals that had reinforcement of the tibia with foam. In the present study, the tibiae were reinforced with foam because (1) lengthening at the site of fixation with tandem screws and washers, interference screw, and WasherLoc in foam-reinforced tibiae from elderly individuals is not substantially different from that in tibiae from young individuals and (2) knees from young individuals are difficult to obtain¹⁵. The increase in the maximal anterior translation after cyclically loading the knee with the spiked washer, interference screw, or WasherLoc in the present study was consistent with lengthening measured in other studies that used either tibiae from young individuals or more dense porcine tibia^{9,15}.

While the use of a foam-reinforced knee instead of a knee from a young individual had little effect on the loss in intra-articular tension and the increase in maximal anterior translation with the spiked washer, interference screw, and WasherLoc, the loss in intra-articular tension and the increase in maximal anterior translation might have been excessive with the double staples. We followed the manufacturer's recommended technique of predrilling the holes, which prevented the bone from fracturing during impaction of the staples. However, the increase in the maximal anterior translation with predrilling in foam-reinforced tibiae in the present study was greater than the lengthening with predrilling in porcine tibiae⁹, and it was greater than the increase in anterior laxity in a clinical study that placed the same staples without predrilling in bone in young individuals²⁵. This could be the

result of the use of foam-reinforced knees instead of knees from young individuals and from predrilling the holes, which is a step recommended by the manufacturer but one that we do not use in clinical practice.

In summary, the results in the present study suggest a biomechanical explanation for the clinical observations that a single value for a tensile force does not restore anterior laxity for a knee reconstructed with a double-looped tendon graft and that there is variability in anterior laxity after anterior cruciate ligament reconstruction. The present study indicates that tensile force applied to a soft-tissue anterior cruciate ligament graft is not fully transferred intra-articularly and is not maintained during cyclic loading. The transfer of the tensile force into the knee is determined by the direction that the tensile force is applied to the graft, which is determined by the type of tibial fixation device. Surgeons should pay close attention to the technique for inserting the tibial fixation device because the results of this study support the assumption that this step induces the greatest change and variability in the intra-articular tension and maximal anterior translation in the knee reconstructed with a double-looped tendon graft. Cyclically loading the knee causes a further loss in intra-articular tension and an increase in the maximal anterior translation. The results of this study support the assumption that the loss of intra-articular tension can be reduced by the use of fixation devices that resist lengthening at the site of fixation and by limiting cyclic loading of the knee. ■

Dustin M. Grover, MS
Stephen M. Howell, MD
Maury L. Hull, PhD

Department of Mechanical Engineering (S.M.H. and M.L.H.) and Biomedical Engineering Graduate Group (D.M.G. and M.L.H.), University of California, Davis, One Shields Avenue, Davis, CA 95616. E-mail address for M.L. Hull: mlhull@ucdavis.edu

In support of their research or preparation of this manuscript, one or more of the authors received grants or outside funding from The Whitaker Foundation. In addition, one or more of the authors received payments or other benefits or a commitment or agreement to provide such benefits from a commercial entity (Arthrotek, Inc.). No commercial entity paid or directed, or agreed to pay or direct, any benefits to any research fund, foundation, educational institution, or other charitable or nonprofit organization with which the authors are affiliated or associated.

doi:10.2106/JBJS.C.01527

References

- Cunningham R, West JR, Greis PE, Burks RT. A survey of the tension applied to a doubled hamstring tendon graft for reconstruction of the anterior cruciate ligament. *Arthroscopy*. 2002;18:983-8.
- van Kampen A, Wymenga AB, van der Heide HJ, Bakens HJ. The effect of different graft tensioning in anterior cruciate ligament reconstruction: a prospective randomized study. *Arthroscopy*. 1998;14:845-50.
- Yoshiya S, Kurosaka M, Ouchi K, Kuroda R, Mizuno K. Graft tension and knee stability after anterior cruciate ligament reconstruction. *Clin Orthop*. 2002;394:154-60.
- Yasuda K, Tsujino J, Tanabe Y, Kaneda K. Effects of initial graft tension on clinical outcome after anterior cruciate ligament reconstruction. Autogenous doubled hamstring tendons connected in series with polyester tapes. *Am J Sports Med*. 1997;25:99-106.
- Burks RT, Leland R. Determination of graft tension before fixation in anterior cruciate ligament reconstruction. *Arthroscopy*. 1988;4:260-6.
- Karchin A, Hull ML, Howell SM. Initial tension and anterior load-displacement behavior of high-stiffness anterior cruciate ligament graft constructs. *J Bone Joint Surg Am*. 2004;86:1675-83.
- Nabors ED, Richmond JC, Vannah WM, McConville OR. Anterior cruciate ligament graft tensioning in full extension. *Am J Sports Med*. 1995;23:488-92.

- 8.** Giurea M, Zorilla P, Amis AA, Aichroth P. Comparative pull-out and cyclic-loading strength tests of anchorage of hamstring tendon grafts in anterior cruciate ligament reconstruction. *Am J Sports Med.* 1999;27:621-5.
- 9.** Magen HE, Howell SM, Hull ML. Structural properties of six tibial fixation methods for anterior cruciate ligament soft tissue grafts. *Am J Sports Med.* 1999;27:35-43.
- 10.** Roos PJ, Hull ML, Howell SM. Lengthening of double-looped tendon graft constructs in three regions after cyclic loading: a study using Roentgen stereophotogrammetric analysis. *J Orthop Res.* 2004;22:839-46.
- 11.** Drillis R, Contini R. Body segment parameters. New York: School of Engineering and Science Research Division, New York University; Technical Report No. 1166.03; 1996. p 109.
- 12.** Plagenhoef S. Anatomical data for analyzing human motion. *Res Q Exerc Sport.* 1983;54:169-78.
- 13.** Pai YC, Patton J. Center of mass velocity-position predictions for balance control. *J Biomech.* 1997;30:347-54. Erratum in: *J Biomech.* 1998;31:199.
- 14.** Melby A 3rd, Noble JS, Askew MJ, Boom AA, Hurst FW. The effects of graft tensioning on the laxity and kinematics of the anterior cruciate ligament reconstructed knee. *Arthroscopy.* 1991;7:257-66.
- 15.** Bailey SB, Grover DM, Howell SM, Hull ML. Foam-reinforced elderly human tibia approximates young human tibia better than porcine tibia: a study of the structural properties of three soft tissue fixation devices. *Am J Sports Med.* 2004;32:755-64.
- 16.** Simmons R, Howell SM, Hull ML. Effect of the angle of the femoral and tibial tunnels in the coronal plane and incremental excision of the posterior cruciate ligament on tension of an anterior cruciate ligament graft: an in vitro study. *J Bone Joint Surg Am.* 2003;85:1018-29.
- 17.** Donahue TL, Gregersen C, Hull ML, Howell SM. Comparison of viscoelastic, structural, and material properties of double-looped anterior cruciate ligament grafts made from bovine digital extensor and human hamstring tendons. *J Biomech Eng.* 2001;123:162-9. Erratum in: *J Biomech Eng.* 2001;123:523.
- 18.** Morrison JB. Function of the knee joint in various activities. *Biomed Eng.* 1969;4:573-80.
- 19.** Bellemans J, Eid T, Fabry G. A modified technique for tibial interference screw fixation of hamstring anterior cruciate ligament grafts. *Arthroscopy.* 1999;15:669-71.
- 20.** Sequeira MM, Rickenbach M, Wietlisbach V, Tullen B, Schutz Y. Physical activity assessment using a pedometer and its comparison with a questionnaire in a large population survey. *Am J Epidemiol.* 1995;142:989-99.
- 21.** Singhatat W, Lawhorn KW, Howell SM, Hull ML. How four weeks of implantation affect the strength and stiffness of a tendon graft in a bone tunnel: a study of two fixation devices in an extraarticular model in ovine. *Am J Sports Med.* 2002;30:506-13.
- 22.** Rodeo SA, Arnoczky SP, Torzilli PA, Hidaka C, Warren RF. Tendon-healing in a bone tunnel. A biomechanical and histological study in the dog. *J Bone Joint Surg Am.* 1993;75:1795-803.
- 23.** Zacharias I, Howell SM, Hull ML, Lawhorn KW. In vivo calibration of a femoral fixation device transducer for measuring anterior cruciate ligament graft tension: a study in an ovine model. *J Biomech Eng.* 2001;123:355-61.
- 24.** Howell SM, Taylor MA. Brace-free rehabilitation, with early return to activity, for knees reconstructed with a double-looped semitendinosus and gracilis graft. *J Bone Joint Surg Am.* 1996;78:814-25.
- 25.** Howell SM, Deutsch ML. Comparison of endoscopic and two-incision techniques for reconstructing a torn anterior cruciate ligament using hamstring tendons. *Arthroscopy.* 1999;15:594-606.
- 26.** To JT, Howell SM, Hull ML. Contributions of femoral fixation methods to the stiffness of anterior cruciate ligament replacements at implantation. *Arthroscopy.* 1999;15:379-87.
- 27.** Kousa P, Jarvinen TL, Vihavainen M, Kannus P, Jarvinen M. The fixation strength of six hamstring tendon graft fixation devices in anterior cruciate ligament reconstruction. Part I: femoral site. *Am J Sports Med.* 2003;31:174-81.
- 28.** Goss BC, Hull ML, Howell SM. Contact pressure and tension in anterior cruciate ligament grafts subjected to roof impingement during passive extension. *J Orthop Res.* 1997;15:263-8.
- 29.** Ventura CP, Wolchok J, Hull ML, Howell SM. An implantable transducer for measuring tension in an anterior cruciate ligament graft. *J Biomech Eng.* 1998;120:327-33.